

## GM 251.X– Data Sheet

Clamping force	12 kN
Product volumes	0–0,35 l
Shuttle stroke	150 mm
<b>Extruder information</b>	<b>Single station machine</b>
Screw diameter	25 mm
Extruder drive output	4 kW
Extruder output HD-PE	7 kg/h
<b>Drive</b>	<b>hybrid</b>
Mould closing	pneumatic
Carriage movement	electric
Blow pin movement	electric
Parison cutter	pneumatic
Deflashing	pneumatic
Extruder bobbing	pneumatic
Wall thickness control	electric
<b>Dimensions</b>	
Width	900 mm
Length	1 700 mm
Height	2 100 mm
Weight	800 kg

### Standard machine features

- machine design based on over 30 years of experience
- automatic extruder revolution control for precise cycle stability and product quality
- optical sensor of parison length allows direct mould closing for exact position of the parison in the mould
- timer machine mode allows automatic run of the machine, regardless of parison length
- interruption of the automatic machine run causes stop of the extruder and starts the alarm
- the machine is equipped with total cycle counter and daily counter with reset option
- machine is equipped with storage for multiple product data recipes
- every machine is custom made according to customers requirements

### Optional features for extra cost

- electric parison 100 point wall thickness control with high precision
- PID temperature controlled feeding zone for steady extruder output
- leak testing unit, which secures output of precise product only
- remote checking of the machine by modem, NET or GSM connection is possible

### Main components

SMC, EXLAR, NORD, SANKYO Oilless Industry, Ziehl – Abegg, Wittmann, OMRON, JUMO, Dynisco, Eaton, Murr...

Mould dimensions	2 Cavities	3 Cavities	4 Cavities	5 Cavities
Standard center distance	50 mm	-	-	-

# GM250

## Extrusion blow moulding machines

GDK spol. s r.o., Czech Republic, 362 14 Kolová 181  
tel. / fax +420 353 331 391, [www.gdk.cz](http://www.gdk.cz)

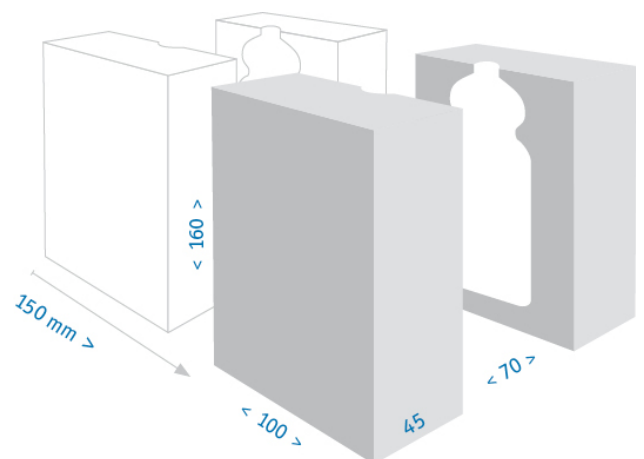

**GDK** Custom Made!